

INSTRUCTION & MAINTENANCE MANUAL

Techtrol Level Controller - TLC-F



Innovating Level Controls since 1984

Techtrol Level Controller TLC-F be used in conjunction with Float Switch (FGSO / FGSI) or magnetic gauge with switch (MLG). It amplifies the signal received from reed switch to operate auxillary devices of higher ratings and to indicate status in control room. It is available as Panel or Wall Mounting (IP 65) with option of Ex-proof Gr IIA & IIB.

Pre Installation Check :

I) Independent Mode :

- Connect controller "TLC-F" to "Supply" and ensure that its "LED glows".
- Connect wire to terminal "C" of controller and connect its open end to all the terminals individually (one by one) and ensure that their respective "LED's glow" and relay contacts change over.
- The controller is ready for installation on above results being positive.

II) Latched Mode :

- To ensure "L1" & "L2" are in latched mode, connect controller "TLC-F" To "Supply" and ensure that its "LED glows".
- Connect wire to terminal "C" of controller and connect its open end to terminal "1".
- Ensure "RL1" contacts change over thru glow on LED "L1". Now remove the wire from terminal "1" and observe that LED "L1" still glows. However on connecting the wire to terminal "2" LED "L1" will stop glowing and LED "L2" will glow.
- Repeat above procedure "b" & "c" for ensuring latching of levels L3 and L4.

Termination

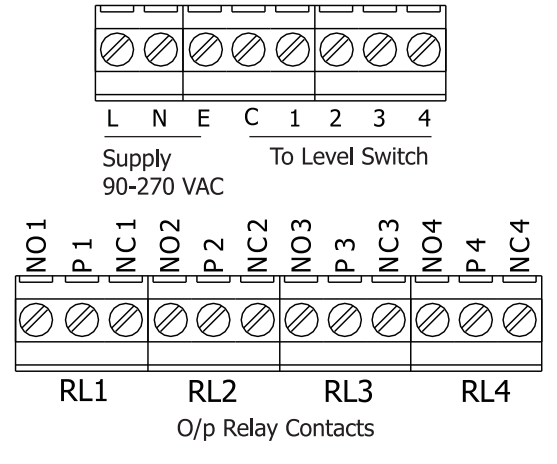

Installation Procedure :

Panel Mounted : Identify the mounting position & prepare a 68 x 68mm "cut out" on panel. Mount controller from front and secure it in place, thru fixing clamps.

Wall Mounted : Mount controller on the "identified position" and secure it thru four mounting holes provided on enclosure. Also ensure following :

- Mounting surface is flat & not subjected to vibrations.
- It is not in close proximity to "high voltage cables", "contactors or drive controls".
- Should not be mounted in a "confined space" where temperatures may exceed the rated temperature.
- Outdoor installation must be protected from "direct sunlight" or "severe weather conditions" thru shield.

FRONT VIEW

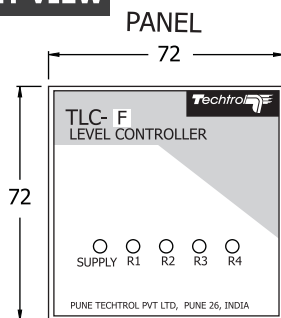

Panel Cutout

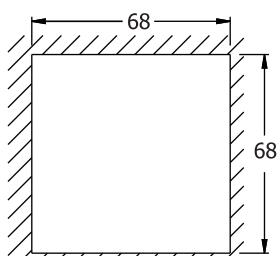

WALL (W. PROOF)

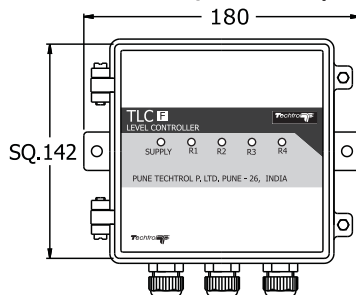

Configuration of drilled holes.

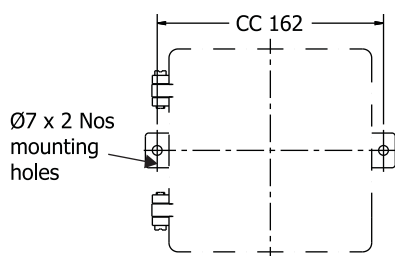

WALL (EX PROOF)

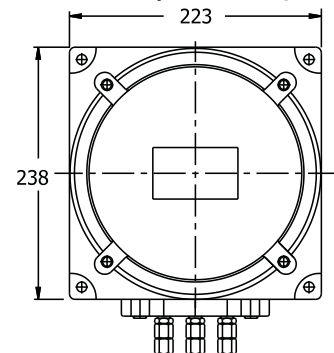

Ø10 x 4 Nos
Mounting
holes

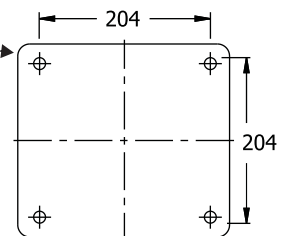

Terminal wiring :  FGSO

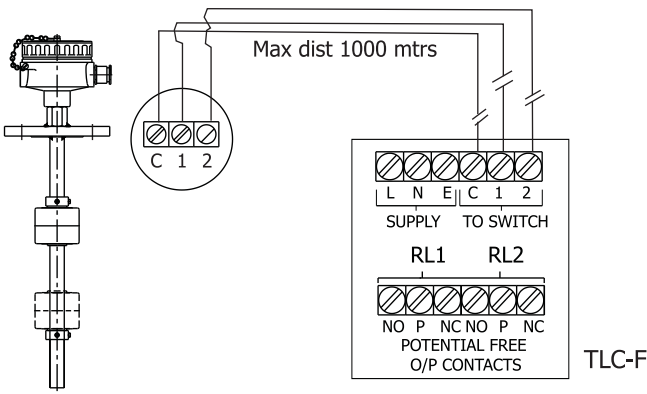

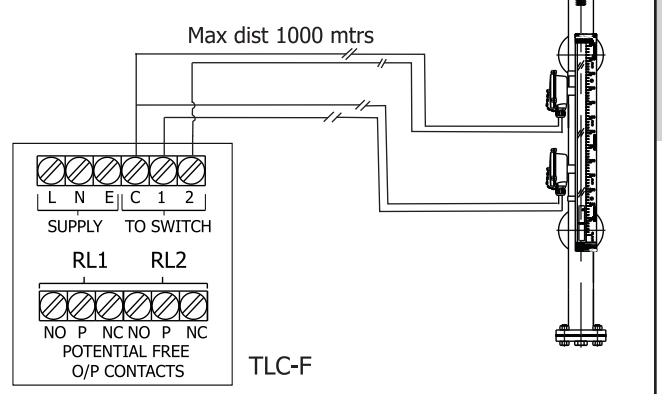

MLG



Converting "Unlatched mode" to "Latched mode" :

Techtrol controller is provided with "4-way Dip Switch" to enable the user to achieve "Latching Mode"

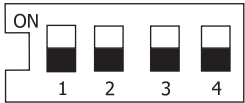
Techtrol controller is supplied in "Unlatched Mode" between preset levels. However, it is provided with a "4 way Dip Switch" to achieve latching between preset levels if required. To achieve "Latch Mode" adopt following procedure tabulated below :

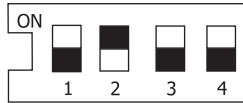
Switch Mode	Unlatched mode	Latch mode (L1 & L2)	Latch mode (L3 & L4)
Key Position on DIP Switch			

Remarks : Other "latching modes" consult factory

Precautions : (please ensure the following) 

- "Supply voltage" & "current" in excess of rated capacity will permanently damage the circuit.
- Controller is "properly earthed".
- In case of Wall mounted version, Enclosure is closed with its protective cover & gasket and there is "NO GAP" between "CABLE OD" and "CABLE GLAND ID" for weather proofness (IP-65).
- In "hazardous locations" do not remove the enclosure cover before disconnecting switch from supply and carry out maintenance there after to prevent any ignition resulting in explosion.
- The supply wiring should be routed away from the power cable, electromagnetic contactors, power relays & motors nearby.
- Do wiring as per standard electrical code and select proper cable to match connected load.
- Switch "ON" the "power supply" only after that all the electrical connections have been completed.

Periodic Maintenance :

- Tighten terminal screws, if loose.
- Visually examine its PCB for any damage.
- Close enclosure with its protective cover after maintenance.
- Controller cleaning from inside for removal of dust or foreign particles.

Trouble Shooting :

Problem	Cause	Solution
Preset Level LED's OFF	Improper wiring Improper supply Blown fuse	Rewire correctly as per "terminal wiring". Use correct supply as specified. Replace fuse. (500 mA)
No change in level/ Relay operations.	Improper wiring	Rewire correctly as per "terminal wiring".
Improper Relay operation	DIP switch setting not proper	Reset DIP switch
Repeated blowing of fuse	Improper or fluctuating supply or spikes in supply or presence of metal debris inside enclosure	Use correct supply as specified. Clean enclosure from inside by using compressed air.

PUNE TECHTROL PVT LTD

S-18, MIDC, Bhosari, Pune : 411026 India

☎ +91-20-66342900, 27121052

☎ 66342998

✉ ho@punetechtrol.com

🌐 www.punetechtrol.com



R A T E D

NSIC-CRISIL SE-1A